

Biocamini da parete / Wall Bio-Fireplaces

## DESCRIZIONE / DESCRIPTION

- > Struttura in acciaio verniciato / *Painted steel structure.*
- > Uso da interno - esterno (protetto) / *Indoor - Outdoor use. (Safe)*
- > Combustibile bioetanolo / *Bioethanol fuel.*
- > Bruciatore circular fibra 12 / *Circular fibra 12 burners*
- > Unità mobile / *Portable unit.*
- > Nessuna predisposizione richiesta / *No hard connection required.*
- > Ecologico / *Eco-friendly.*
- > Compreso asta spegnifiamma / *Flame - extinguishing rod included.*
- > Compreso staffa a muro / *Wall fixing braket included*

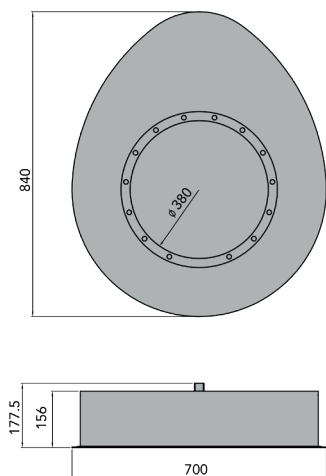

DATI TECNICI / Technical data	ELLIPSE
Capacità / Capacity	0.9 l
Durata / Burning Time	3 - 4 h
Potenza Calorica / Heat Output	1,8 kW
Peso / Net Weiting	17 Kg
Finitura / Finish	Bianco, Nero o Rosso / White, Black or Red
Finitura / Finish	Optional: A Mano Corten o Acciaio Inox Satinato / Corten Hand Finish or Brushed stainless steel