

# Ballon

# De

# Paris



# Since 1921 Paris, France

<BallondeParis> is a premium audio brand,

We produce high-end speakers that combine the technology and design of the Garrel family, which has been handed down since 1921.

Louis Garrel and his brothers, who founded <BallondeParis>,

had problems breaking the sound of a particular range of violin at the time.

It studied and solved, minimized distortion of sound and was praised by many violinists.

Introducing 100 years of technology and attractive design, <BallondeParis> is newly launched.

It's not just a brand that makes speakers, but an object that evolves with changing interior design,

It gives users a special experience that won't get bored for a long time.

<BallondeParis> has won the grand prize at world-class design awards such as France and Italy

It is a proven high-end sound brand that many audio enthusiasts can find quite attractive.



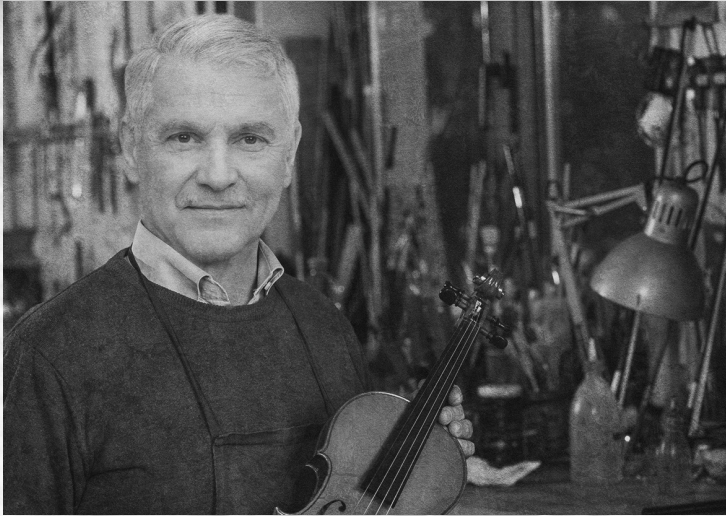

## Founder Louis Garrel (1883 ~ 1946)

After learning violin making for 19 years at a violin workshop from 1901, Louis Garrel and his brothers established <Ballondeparis>, the string instrument workshop in 1921 to research violin making and sound. Louis Garrel, who succeeded in returning distorted sounds to normal through "Vicugna Wool" in 1920, was officially recognized for his technique in 1945 and was recorded as someone who left a mark on the production of string instruments.

French Patent Registration



## Designer Raphael Garrel (1957 ~ )

Raphael Garrel, majored in industrial design, is the fourth generation of the Garrel family. He produces the speakers by combining design with family technology, with his brother Julien Garrel, a tuner who inherited the skills.

This was the beginning of <Ballondeparis> speakers.

BALLON  
DE PARIS



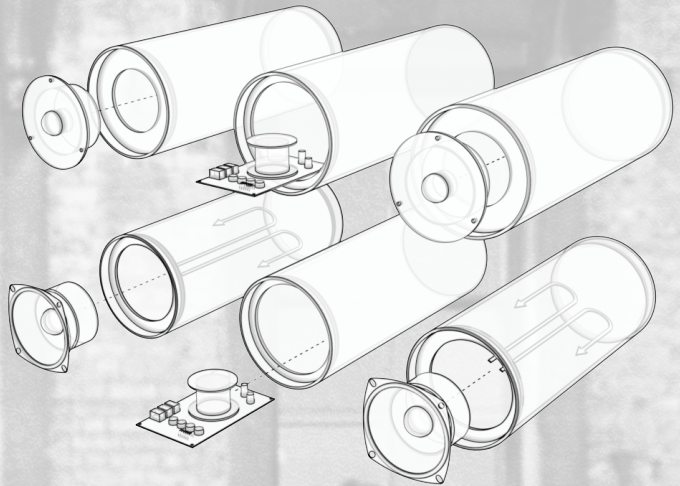

## Independent Sound Tube

"Julien Garrel", the family's 4th generation engineer, found out that when sound meets a corner inside a speaker, the sound is reflected irregularly, causing problems in the sound range.

After a long period of research, he researched a pipe-shaped structure with the least distortion, minimizing sound distortion. This technology is officially recognized as the greatest innovation in modern speaker technology.

France patent Certificate Number (SMS.W.I./17587/C.O)

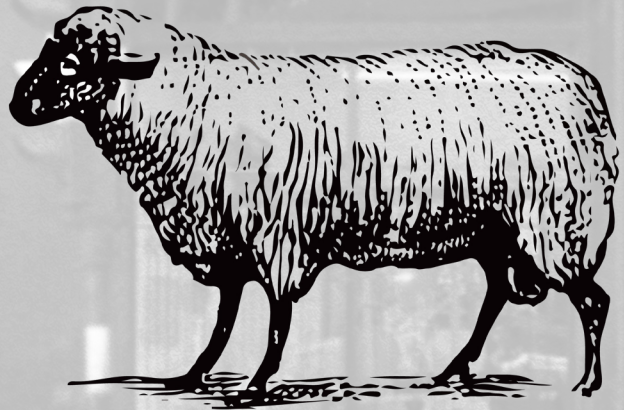

## Vicuna Wool technology

Vicugna wool, called fiber of God, is a premium wool with less than 0.1% production. High-density fiber increases sound absorption and removes noise, showing excellent performance in low, medium, and high sounds. The technology was officially recognized in 1945 and succeeded in long-term preservation of Vicugna wool with low production and a short shelf life through research by descendants. Vicugna wool technology has been incorporated into the object series and has continued to this day.

patent Application Number (PATENT -2022-0186106 H04R 1/02)

# Object Series



## Object Series

This is an all-in-one speaker from <BallondeParis>.

It won the grand prize in the audio equipment category at the three major European design awards.

It is loved because it can be used as an object as well as a speaker.

# Object VI

Object VI is Raphael Garrel's signature design.

It changes the atmosphere of the interior with sophisticated resolution that has been advanced for 100 years.

Designed with six independent sound tubes, the VI delivers the most accurate sound to the listener.



# Object IX

IX, The most advanced in the Object series.  
Designed with 9 independent sound tubes for higher output,  
it fills a large space with the richest expressive power.

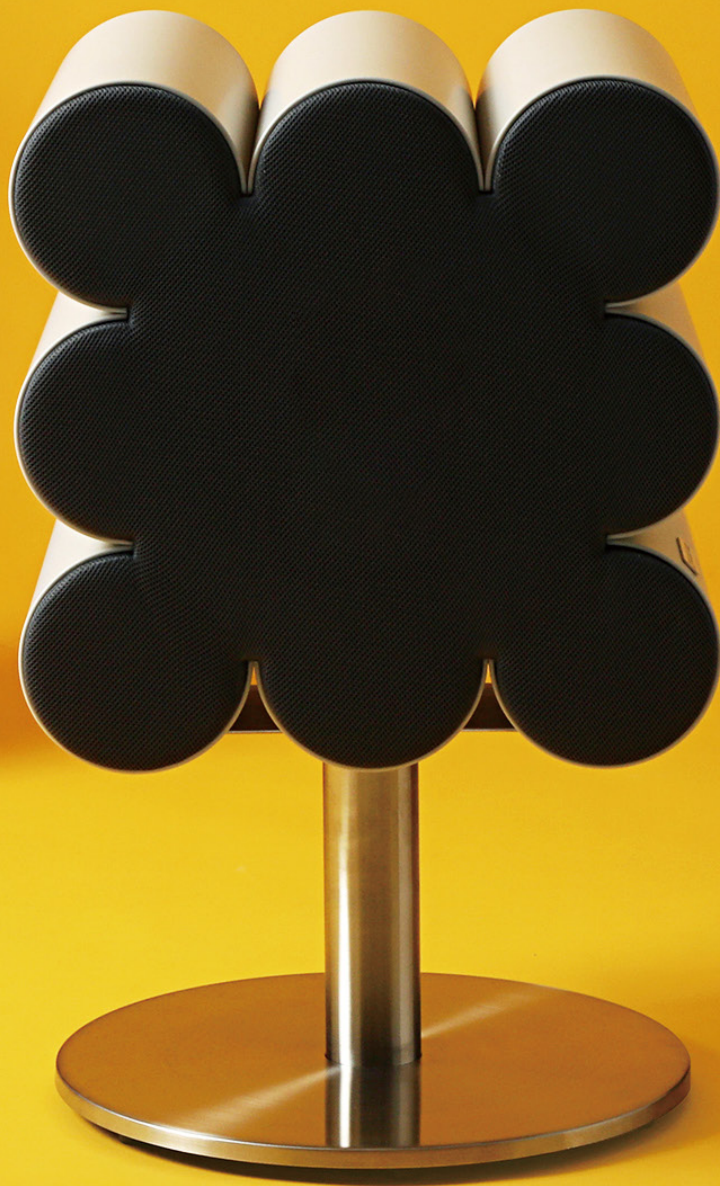

France's DNA PARIS DESIGN AWARD.  
2022 GRAND PRIX in the audio equipment category

Italy's A'DESIGN AWARD.  
2023 GOLD WINNER in the audio equipment category

# Europe's top three DESIGN AWARDS Winner 2023

2022 DNA Paris Design Awards \_ Grand Prix \_ Paris  
2023 A` Design Award & Competition \_ Gold \_ Italy

DNA Paris Design Awards is an accolade honoring the work of international architects and designers, who improve our daily lives through practical, beautiful and innovative design.



# Brand Collaboration

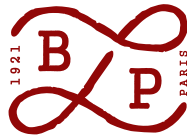

X



All the sound equipment in <BallondeParis> is made by the hands of the masters of <Analogizm>.



Sound Engine 2018  
LG Collaboration

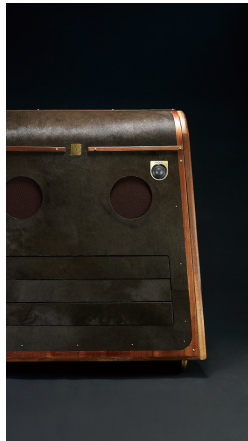

Golden Saddle 2017  
Louis Quatorze Collaboration

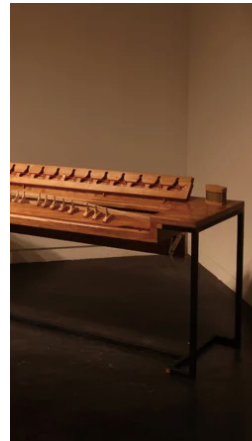

Ak Sang 2014  
Louis Vuitton Collaboration

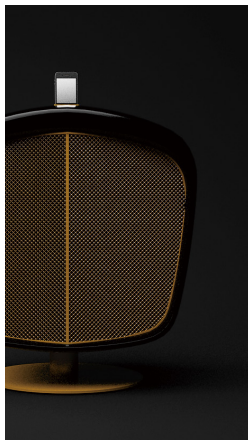

Sound Engine 2018  
Lie Sang Bong Collaboration



Karim Rashid Edition 2017  
Karim Rashid Collaboration



D.Horn 2017  
Ballantine's Collaboration

# Brand History



<Analogizm> collaborating with <BallondeParis> is a group that produces sound equipment as a work of art.



Butter Fly 2004



Airplane 2005



Organism I 2006



Organism II 2008



Collection 1902 2010



Golden Triangle 2011



Golden Bug 2012



Organism II 2013

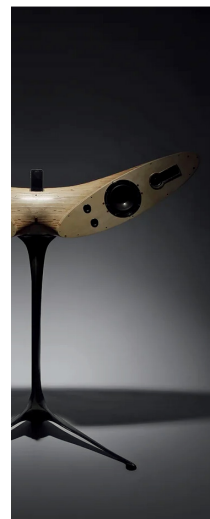

Butterfly III 2015

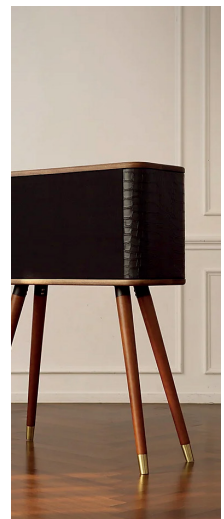

Collection M 2019

# Brand History

## Ballondeparis x Analogizm

<Analogizm>, which is in charge of designing and producing all the products of <BallondeParis>, is a high-end sound equipment production brand representing Korea where artisans from various fields gather and is recognized for its continuous collaboration with world-class luxury brands and designers.

The sound equipment of <Analogizm>, which is already dominating the world-class design awards, is a work of art and is owned by world-renowned state guests such as Putin of Russia and the Crown Prince of Denmark to prove its value.



**Vladimir Putin**  
President of Russia

"Ak Sang", 2016



**Frederik Christian**  
Crown prince of Denmark

"Collection A", 2016

Collection A - hyundai (2020) , SK (2020), LIG (2020), LG(2019)  
Golden Saddle - \*\*lee (North Korea 2019)  
Single Dofa - Donald \*\*\*\*\* (USA 2019)

Please excuse blurring the restricted document.

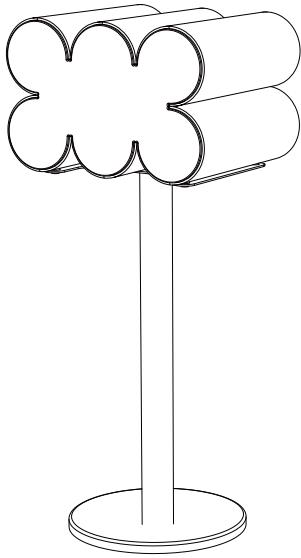

Object 6

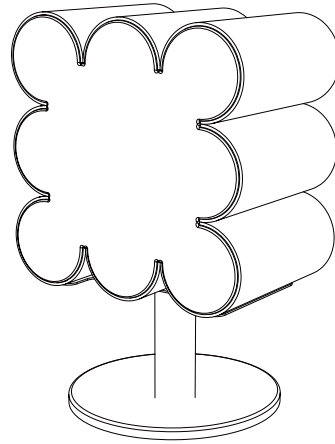

Object 9

Interface		
Audio Input	AUX(3.5mm)	maximum 1V RMS input
	USB	PC connected (16bit/44.1kHz)
	Bluetooth 5.0	AAC, SBC
Connectivity	WI-FI	2.4G
	LAN	RJ45
Speaker output		
Object 6	68W @8Ω stereo	
Object 9	180W @8Ω stereo	
General		
Power Supply System	AC100-240V 50/60Hz 1A	
Volume Knob	Volume Control	
Signal-to-Noise Ratio	≥85dB @ maximum	
THD+N	<0.9% @ 1KHz,1W	
Crosstalk	>55dB @ 1KHz	
Speaker Dimensions	Object 6 - W420 X D360 X H280mm (12kg), Object 9 - W495 X D330 X H495 (18kg)	
Stand Dimensions	Object 6 - W350 X D350 X H710mm (11kg), Object 9 - W400 X D400 X H245 (12kg)	

black@analogizm.com  
www.ballondeparis.fr



BALLON  
DE PARIS